

SWL 高剛性・高扭矩聯軸器 / High Rigid, High Torque

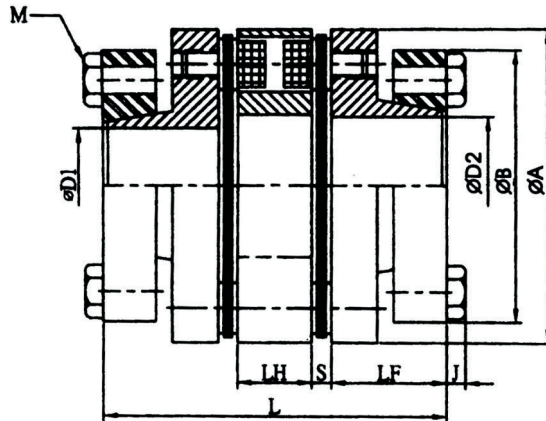

SWL- - -
 外徑 Diameter D1 D2

◆尺寸表 / Dimension

單位/unit:mm

規格 No.	A	B	D1		D2		L	LF	LH	S	J	M	螺絲鎖緊力 Screw Tightening Moment
			min	max	min	max							
SWL-40	40	38	8	16	8	16	49.2	16	10	3.6	2.8	8-M4	3.5Nm
SWL-56	56	48	10	17	10	17	60.9	20	13	3.9	4	8-M5	6Nm
		54	18	25	18	25							
SWL-68	68	54	14	22	14	22	74.5	25	16	4.2	4.2	8-M6	12Nm
		64	24	30	24	30							
SWL-82	82	56	16	22	16	22	85	30	16	4.8	4	8-M6	12Nm
		64	24	30	24	30							
		69	32	35	32	35							
SWL-94	94	58	19	22	19	22	100.8	30	22	9.4	4	8-M6	14Nm
		68	24	30	24	30							
		78	32	40	32	40							
		88	42	48	42	48							
SWL-104	104	68	24	30	24	30	102	30	22	10	4	8-M6	14Nm
		78	32	40	32	40							
		88	42	50	42	50							
		98	55	60	55	60							

◆特性表 / Specification

規格 No.	常用扭力 Rated Torque (Nm)	最高迴轉數 Max. (rpm)	容許偏心 Allowable Eccentricity Error (mm)	容許角度偏差 Allowable Angular Error (°)	容許軸向位移 Allowable Shaft End-Plaw (mm)	彈簧定數 Spring Constant (N-m/rad)	軸向彈簧定數 Shaft Spring Constant (mm)	慣性矩 Moment of Inertia (Kg.m ²)	重量 Weight (g)
SWL-40	7	10000	0.20	單邊1	±0.5	5000	25	2.8 × 10 ⁻⁵	120
SWL-56	25	10000	0.25	單邊1	±0.8	8000	21.5	14 × 10 ⁻⁵	308
SWL-68	60	10000	0.30	單邊1	±0.9	30000	22.5	38 × 10 ⁻⁵	560
SWL-82	90	10000	0.30	單邊1	±0.9	35000	30	107 × 10 ⁻⁵	855
SWL-94	180	10000	0.50	單邊1	±1.6	70000	60	195 × 10 ⁻⁵	1500
SWL-104	250	10000	0.50	單邊1	±1.6	80000	80	210 × 10 ⁻⁵	1700

◆特性 / Features

- 低慣性無背隙 / Low Inertia, Backlash-free
- 具緩衝抗震功能 / Flexibility and Vibration Resistance
- 錐形固定方式安全可靠 / Secured by Conical Clamping
- 適用於伺服馬達或精密定位傳動 / Applicable for Servo Motor or Precision Positioning Transmission
- 免保養壽命長 / Maintenance-free ; Infinite Life
- 本體鋁合金材質輕量化 / Aluminum Alloy Body ; Light-weight