

SD 自動校心型 / Self-centering

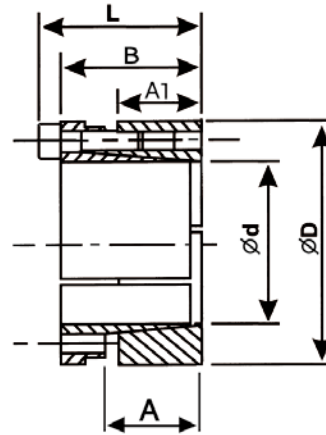

SD-
 內徑 / Inside Diameter

規格 No.	d mm	D mm	A mm	A1 mm	B mm	L mm	M mm	TS Nm	T Nm	F KN	P N/mm ²	重量 Weight Kg
SD-20	20	47	31	26	42	48	6-M6	17	550	55	100	0.37
SD-22	22	47	31	26	42	48	6-M6	17	600	55	100	0.37
SD-24	24	50	31	26	42	48	6-M6	17	660	55	100	0.40
SD-25	25	50	31	26	42	48	6-M6	17	680	55	100	0.40
SD-28	28	55	31	26	42	48	6-M6	17	720	55	100	0.44
SD-30	30	55	31	26	42	48	6-M6	17	820	55	100	0.53
SD-32	32	60	31	26	42	48	8-M6	17	1400	80	130	0.52
SD-35	35	60	31	26	42	48	8-M6	17	1400	80	130	0.50
SD-38	38	65	31	26	42	48	8-M6	17	1600	80	130	0.60
SD-40	40	65	31	26	42	48	8-M6	17	1600	110	130	0.58
SD-42	42	75	36	30	50	58	6-M8	41	2500	110	130	1.00
SD-45	45	75	36	30	50	58	6-M8	41	2500	150	130	0.97
SD-48	48	80	36	30	50	58	8-M8	41	3700	150	170	1.08
SD-50	50	80	36	30	50	58	8-M8	41	3700	150	170	1.05
SD-55	55	85	36	30	50	58	8-M8	41	4100	150	160	1.14
SD-60	60	90	36	30	50	58	8-M8	41	4500	160	160	1.18
SD-65	65	95	36	30	50	58	8-M8	41	4500	160	150	1.26
SD-70	70	110	46	39	60	70	8-M10	83	8400	240	150	2.25
SD-75	75	115	46	39	60	70	8-M10	83	8400	240	140	2.43
SD-80	80	120	46	39	60	70	10-M10	83	9600	250	140	2.60
SD-85	85	125	46	39	60	70	10-M10	83	11000	250	150	2.70
SD-90	90	130	46	39	60	70	10-M10	83	13000	300	150	2.80
SD-95	95	135	46	39	60	70	10-M10	83	13000	300	150	3.00
SD-100	100	145	52	46	68	80	10-M12	145	17500	350	150	4.10
SD-110	110	155	52	46	68	80	10-M12	145	20000	300	150	4.40
SD-120	120	165	52	46	68	80	10-M12	145	21300	330	150	4.80
SD-130	130	180	52	46	68	80	12-M12	145	28000	350	150	5.70
SD-140	140	190	58.5	51	76	90	12-M14	190	30400	350	150	6.20
SD-150	150	200	58.5	51	76	90	12-M14	190	39000	400	160	7.10
SD-160	160	210	58.5	51	76	90	12-M14	190	41700	400	170	8.00
SD-170	170	225	58.5	51	76	90	14-M14	190	52000	460	160	11.00
SD-180	180	235	58.5	51	76	90	14-M14	190	55000	460	170	12.10

★本產品提供客製無電解鍍和鍍鋅服務 / Electronless Nickel Plating or Galvanized is optional