

SES 自動校心型 / Self-centering

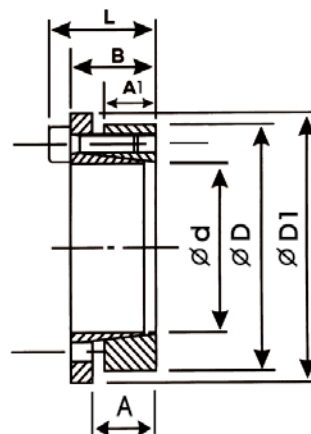

SES-
內徑 / Inside Diameter

規格 No.	d mm	D mm	D1 mm	A mm	A1 mm	B mm	L mm	M mm	TS Nm	T Nm	F KN	P N/mm ²	重量 Kg
SES-08	8	22	25	13	10	17	21	3-M4	3.9	18	4.7	70	0.03
SES-10	10	24	27	13	10	17	21	4-M4	3.9	30	6.2	87	0.06
SES-11	11	25	28	13	10	17	21	4-M4	3.9	34	6.2	84	0.06
SES-12	12	26	29	13	10	17	21	5-M4	3.9	47	7.8	100	0.07
SES-13	13	27	30	13	10	17	21	5-M4	3.9	50	7.8	97	0.08
SES-14	14	31	34	16	12.5	21	26	4-M5	8	70	10	87	0.08
SES-15	15	32	35	16	12.5	21	26	4-M5	8	75	10	84	0.08
SES-16	16	33	36	16	12.5	21	26	4-M5	8	80	10	81	0.08
SES-17	17	34	37	16	12.5	21	26	6-M5	8	105	12.5	99	0.09
SES-18	18	35	38	16	12.5	21	26	6-M5	8	110	12.5	96	0.10
SES-19	19	47	56	22	17	28	34	6-M6	17	290	30	100	0.26
SES-20	20	47	56	22	17	28	34	6-M6	17	320	32	100	0.25
SES-22	22	47	56	22	17	28	34	6-M6	17	320	32	100	0.25
SES-24	24	50	59	22	17	28	34	6-M6	17	360	32	100	0.27
SES-25	25	50	59	22	17	28	34	6-M6	17	420	34	100	0.27
SES-28	28	55	64	22	17	28	34	6-M6	17	500	34	100	0.32
SES-30	30	55	64	22	17	28	34	6-M6	17	520	34	100	0.35
SES-32	32	60	69	22	17	28	34	8-M6	17	770	48	110	0.37
SES-35	35	60	69	22	17	28	34	8-M6	17	840	48	110	0.34
SES-38	38	65	74	22	17	28	34	8-M6	17	910	48	110	0.40
SES-40	40	65	74	22	17	28	34	8-M6	17	960	48	110	0.38
SES-42	42	75	84	25	20	33	41	7-M8	41	1000	65	110	0.65
SES-45	45	75	84	25	20	33	41	7-M8	41	1500	65	110	0.63
SES-48	48	80	89	25	20	33	41	8-M8	41	2000	85	140	0.70
SES-50	50	80	89	25	20	33	41	8-M8	41	2100	85	140	0.68
SES-55	55	85	94	25	20	33	41	8-M8	41	2500	95	140	0.73
SES-60	60	90	99	25	20	33	41	8-M8	41	2700	90	130	0.78
SES-65	65	95	104	25	20	33	41	9-M8	41	3200	100	140	0.83
SES-70	70	110	119	30	24	40	50	8-M10	83	4900	140	140	1.33
SES-75	75	115	124	30	24	40	50	8-M10	83	5300	140	130	1.40
SES-80	80	120	129	30	24	40	50	8-M10	83	5600	140	130	1.48
SES-85	85	125	134	30	24	40	50	9-M10	83	6700	160	130	1.55
SES-90	90	130	139	30	24	40	50	9-M10	83	7100	160	130	1.63
SES-95	95	135	144	30	24	40	50	10-M10	83	9100	195	135	1.70
SES-100	100	145	154	32	26	44	56	8-M12	145	10200	200	150	2.60
SES-110	110	155	164	32	26	44	56	8-M12	145	10600	200	150	2.80
SES-120	120	165	174	32	26	44	56	9-M12	145	13000	216	140	3.00
SES-130	130	180	189	40	34	54	64	12-M12	145	18900	290	135	4.60
SES-140	140	190	199	40	34	54	68	9-M14	230	20500	333	125	4.90
SES-150	150	200	209	40	34	54	68	10-M14	230	25000	362	120	5.20
SES-160	160	210	219	40	34	54	68	11-M14	230	29000	362	130	5.50
SES-170	170	225	234	50	44	64	78	12-M14	230	34000	400	135	7.75
SES-180	180	235	244	50	44	64	78	12-M14	230	36000	400	120	8.15
SES-190	190	250	259	50	44	64	78	15-M14	230	47500	500	115	9.50
SES-200	200	260	269	50	44	64	78	15-M14	230	50000	500	140	9.90

★本產品提供客製無電解鍍和鍍鋅服務 / Electronless Nickel Plating or Galvanized is optional