

# SFC/SFCS 止付螺絲撓性聯軸器 / Set Screw, Flexible Coupling

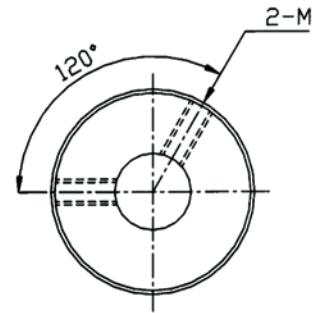
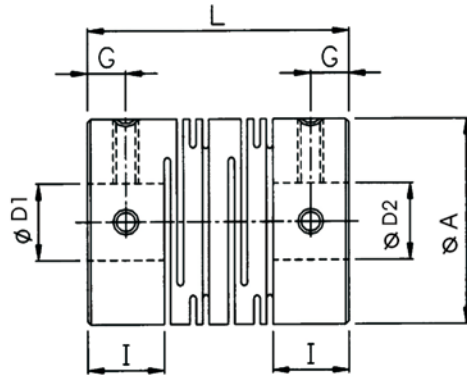

SFC/SFCS-  -  -   
 外徑 D1 D2  
 Diameter

## ◆尺寸表 / Dimension

單位 / unit:mm

規格 No.	A	I	L	G	M	D1×D2		重量 Weight (g)
						min	max	
SFC-16	16	6.5	23	3	M3	4	8	9.5
SFC-20	20	7.5	26	3	M4	5	10	16
SFC-25	25	8.5	31	4	M4	5	12	30
SFC-32	32	12	41	6	M5	6	14	65
SFC-40	40	15	56	8.5	M5	8	20	120
SFC-50	50	18	71	10.5	M6	12	25	230
SFC-63	63	22	90	13	M8	15	35	470
SFCS-16	16	6.5	23	3	M3	4	8	28
SFCS-20	20	7.5	26	3	M4	5	10	45
SFCS-25	25	8.5	31	4	M4	6	12	95
SFCS-32	32	12	41	6	M5	6	14	220
SFCS-40	40	15	56	8.5	M5	8	20	350
SFCS-50	50	18	71	10.5	M6	12	25	700
SFCS-63	63	22	90	13	M8	15	35	1300

## ◆特性表 / Specification

規格 No.	常用扭力 Rated Torque (N.m)	最大扭力 Max. Torque (N.m)	最高轉數 Max. Rotational (rpm)	慣性矩 Moment of Inertia (Kg.m <sup>2</sup> )	剛性靜扭力值 Staic Torional (N.m/rad)	容許偏心 Allowable Eccentricity Error (mm)	容許角度偏差 Allowable Angular Error (°)	容許軸向位移 Allowable Shaft End-Play (mm)
SFC-16	0.3	0.6	24000	$3.3 \times 10^{-7}$	47	0.10	2	±0.4
SFC-20	0.5	1	19000	$9.0 \times 10^{-7}$	120	0.10	2	±0.4
SFC-25	1	2	15000	$2.6 \times 10^{-6}$	170	0.15	2	±0.5
SFC-32	2	4	12000	$9.6 \times 10^{-6}$	280	0.15	2	±0.5
SFC-40	5	10	9600	$3.2 \times 10^{-5}$	350	0.20	2	±0.5
SFC-50	10	20	7700	$1.0 \times 10^{-4}$	590	0.20	2	±0.5
SFC-63	20	40	6100	$3.2 \times 10^{-4}$	850	0.20	2	±0.5
SFCS-16	0.5	1	24000	$8.4 \times 10^{-7}$	85	0.10	2	±0.3
SFCS-20	1	2	19000	$2.4 \times 10^{-6}$	250	0.10	2	±0.3
SFCS-25	2	4	15000	$6.8 \times 10^{-6}$	330	0.15	2	±0.4
SFCS-32	3.5	7	12000	$2.6 \times 10^{-5}$	850	0.15	2	±0.5
SFCS-40	8	16	9600	$8.7 \times 10^{-5}$	1000	0.20	2	±0.5
SFCS-50	15	30	7700	$2.7 \times 10^{-4}$	1400	0.20	2	±0.5
SFCS-63	35	70	6100	$8.4 \times 10^{-4}$	1800	0.20	2	±0.5

SFC：鋁合金材質

Material：Aluminum

SFCS：不銹鋼材質

Material：Stainless